

MICROWAVE SPECTRUM ANALYZER ON A BUDGET

*A practical approach to microwave
signal analysis for the home
experimenter*

Test equipment commonly found in the amateur workshop usually isn't suited for microwave experimentation. The most important piece of equipment for microwave work is a spectrum analyzer. And, while older commercial units are available, they have several shortcomings: they are costly, they may depend upon components that aren't readily

available, and repairs can be expensive. However, there is an alternative. *Ham Radio* magazine described a low-cost spectrum analyzer designed by Murray Barlow, WA2PZO, and built by Robert Richardson, W4UCH,¹ that offered effective spectrum analysis at reasonable cost. The design used cable TV tuners, a 66-MHz IF strip, and sweep circuitry to inter-

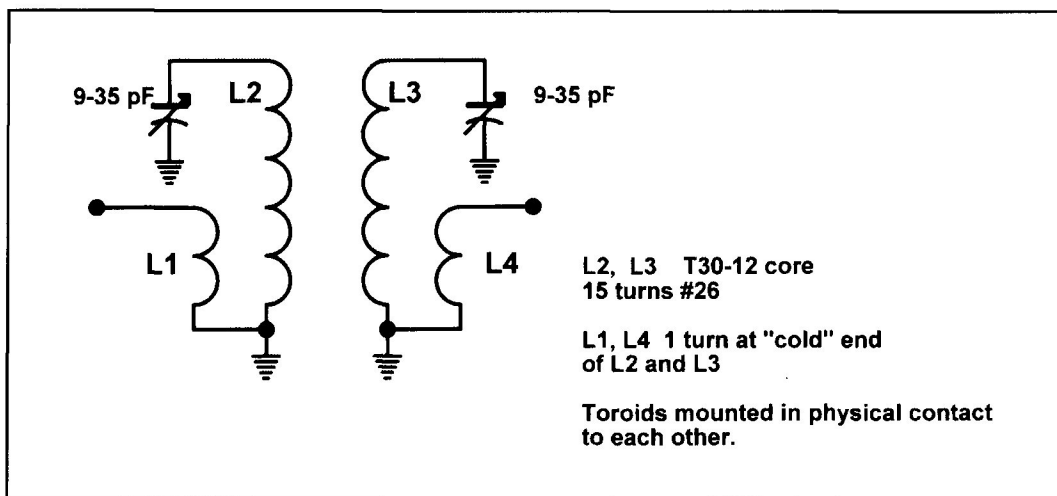

Figure 1. Double-tuned circuit.

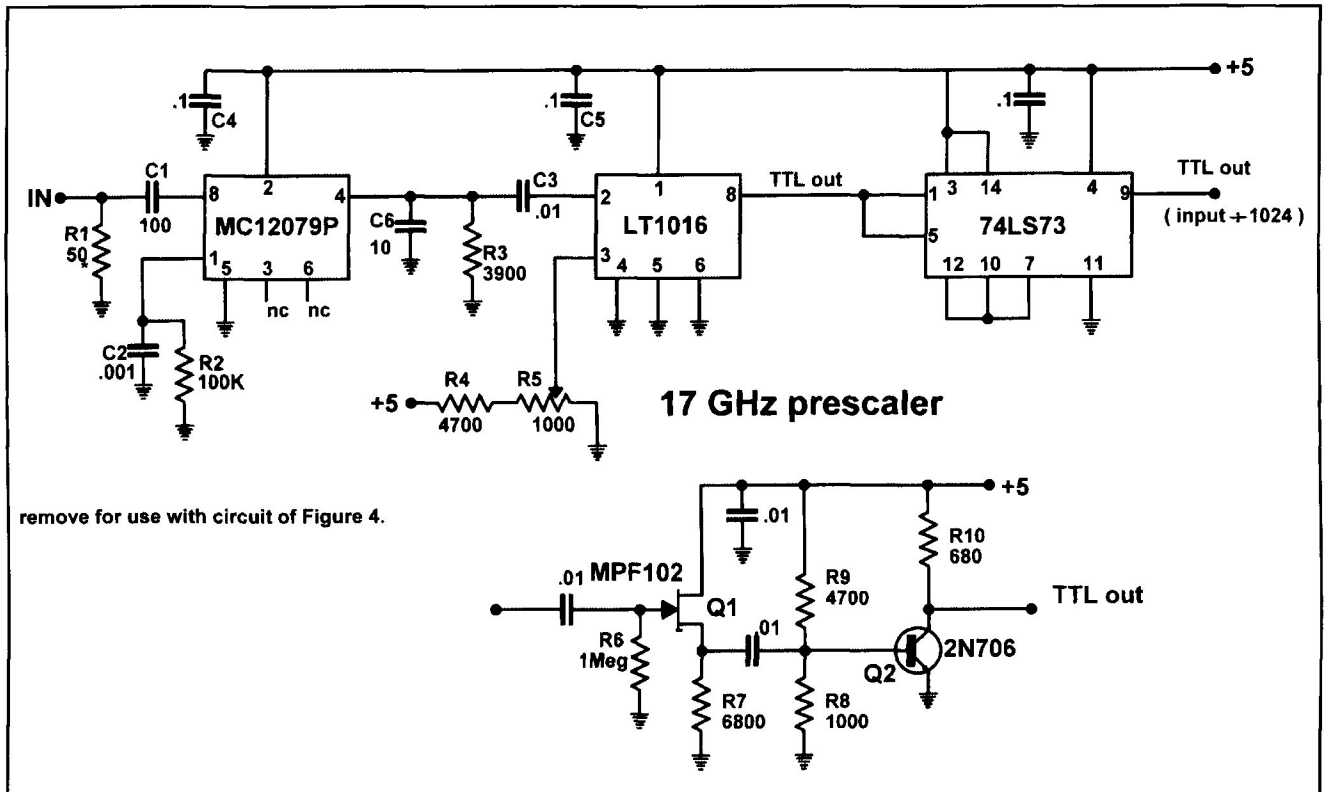

Figure 2. Prescaler built around a MC12079.

face with an oscilloscope. An option permitted coverage of the 1 to 1.75-GHz range. I'll show how to extend that range to higher frequencies.

The schematic of the IF strip of WA2PZO's analyzer shows that the 66-MHz IF stage uses a balun input. I added a double-tuned circuit

(Figure 1) to provide enough selectivity to attenuate image responses. The filter is built "surface-mount" fashion on a small section of printed circuit board, with the two toroids mounted in physical proximity. The board is mounted in the enclosure housing the IF strip.

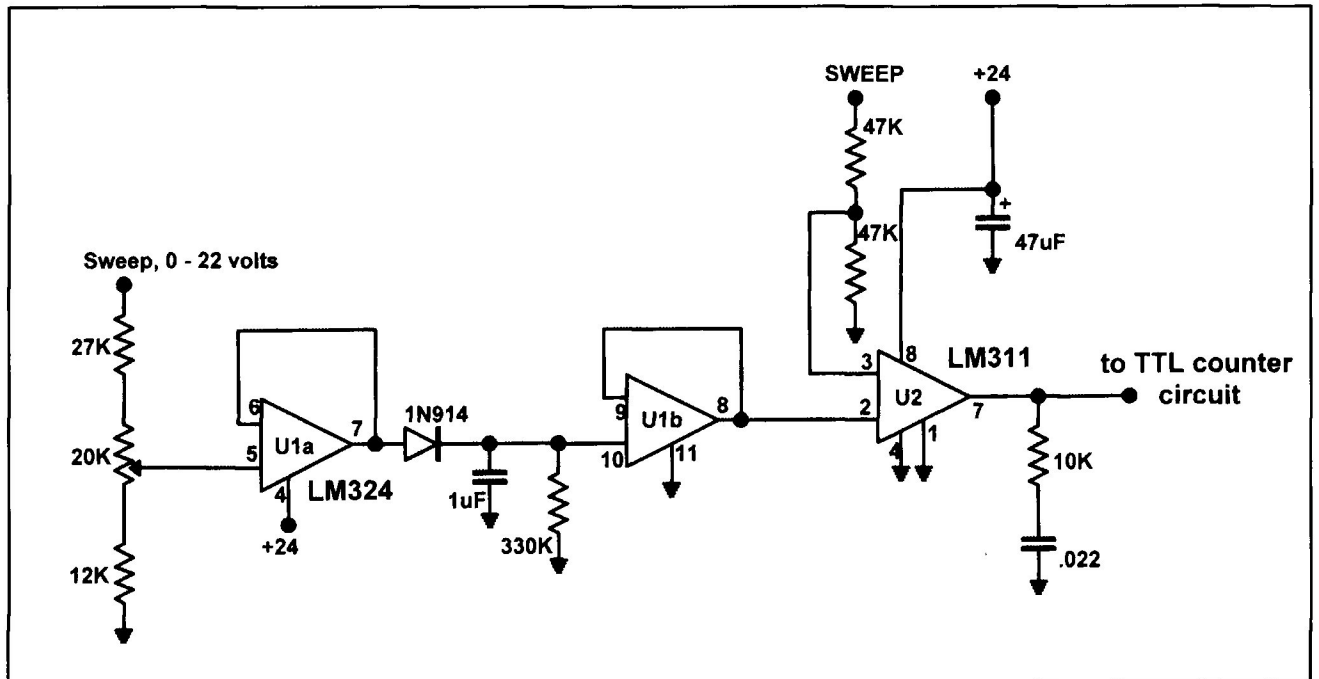

Figure 3. Peak detector.

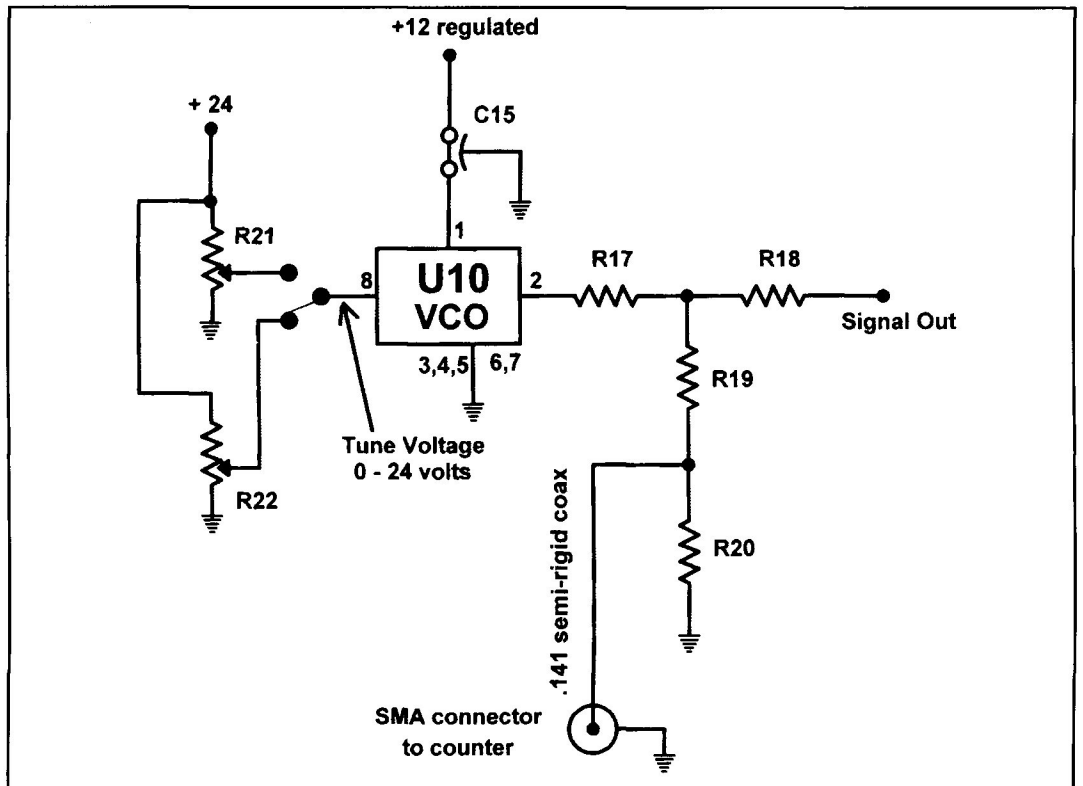

Figure 4. Simple generator capable of 940-2300 MHz.

Once the board is placed in the enclosure, images can be tuned out.

The next problem is to determine the frequency to which the analyzer is tuned. The tuner provides a sample port (RCA jack) to allow the use of a prescaler. A number of prescaler chips are available for operation to 3 GHz or higher. **Figure 2** shows a circuit built around the MC12079. This device contains a very sensitive on-chip preamp, and divides by 256 in this application. An additional divide-by-four circuit yields a final divide ratio of 1024; this can be fed to the counter circuit found in **Reference 2**.

The prescaler and counter

The prescaler was assembled on 0.06-inch G10 epoxy circuit board. The chip comes in an 8-pin DIP package. The input trace must be kept very short. I used an SMA receptacle on the enclosure, made of 0.039-inch circuit board. This was attached to the tuner using a 1-1/2 inch length of RG-174 coax with an RCA fitting. This may be a bit unorthodox, but it works. Note that pin 1 of the MC12079 should be biased through a 100-k resistor to either Vcc or ground to prevent oscillation.

At first the tuner was unable to drive the prescaler at frequencies near 1600 MHz. I traced the problem to the 100-ohm carbon film

resistor used to sample the RF. It had long leads, one of which was connected to ground and the other to the output jack. Replacing it with a carbon composition resistor solved the problem.

Once the prescaler and counter were operating, I had to determine where the readout was sampling along the frequency continuum. **References 2 and 3** assume a center frequency can be determined by calibration. I wasn't able to get that approach to work and devised the circuit shown in **Figure 3**. This is a peak detector that permits the comparator, U2, to start the frequency sample at a point which can be adjusted up to the approximate apex of the sweep waveform. When adjusted, a signal appearing on screen at the far right is reliably indicated by the readout—regardless of the settings of the other sweep controls.

The counter is designed to read out the LO frequency. By using preloading counter chips, as shown in **Reference 3**, the actual signal frequency can be displayed. This will work for the 0.9 to 1.75-GHz tuner. Otherwise, it is necessary to subtract 66 from the readout to determine the frequency.

A simple signal generator

There's another approach which is desirable for units using this tuner as a fixed IF. By con-

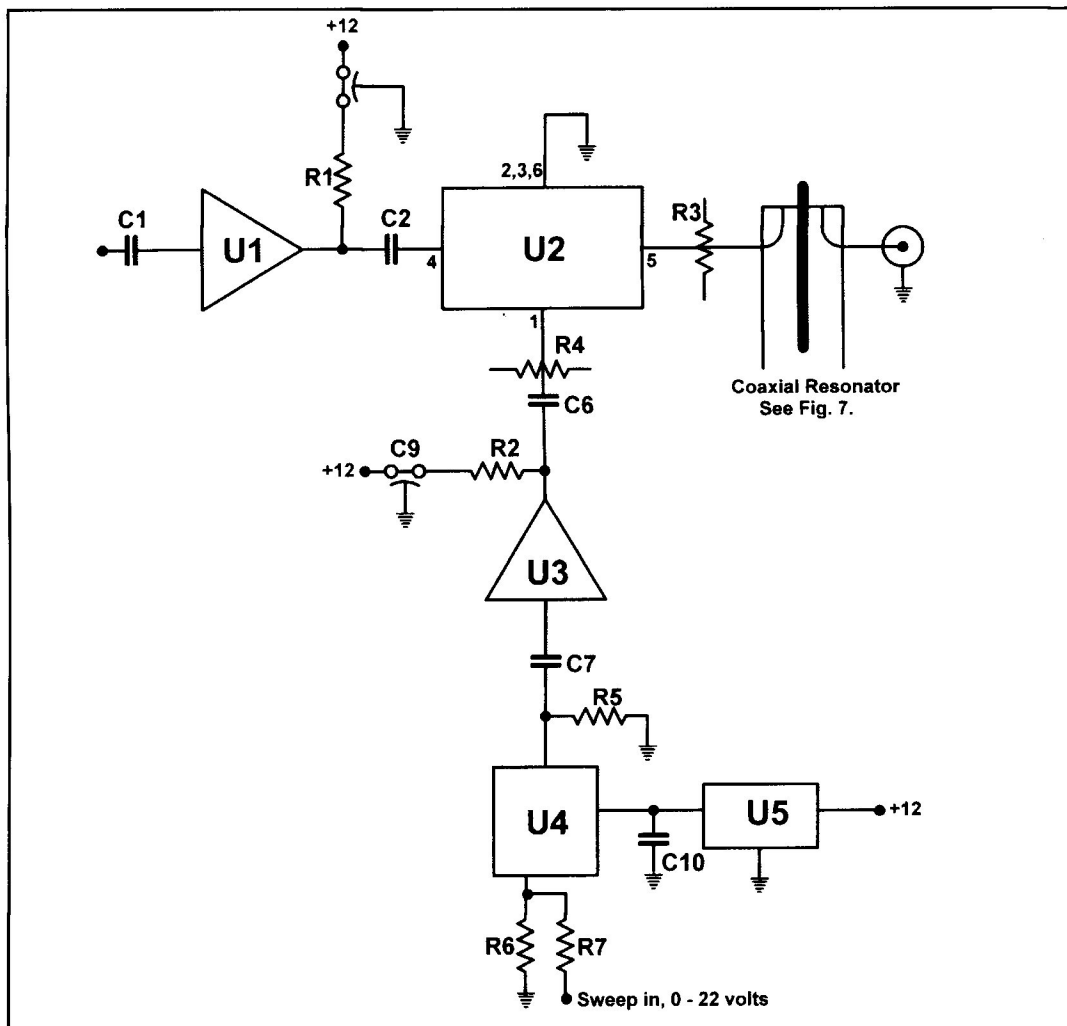

Figure 5. Method for reaching higher frequencies.

necting a signal generator to the counter, with low level injection to the converter input, you can read out the frequency at any point on the screen with accuracy. I constructed a simple generator using the MiniCircuits POS 2120W VCO* that tunes from 940 to 2300 MHz, as detailed in Figure 4. When placed in the vicinity of the analyzer, it produces a low-level trace on the scope display. At this point, it's only necessary to move the generator blip to coincide with the unknown signal blip to readout the frequency.

I used the sweep board from Science Workshop.** I found it helpful to look at the sweep output on a scope while varying the controls to better understand what I was seeing on the screen. Many settings of the rate, width, and tuning yield a sweep of constant amplitude and a trace with no signals. It's possible to adjust the controls so the entire sweep range is available and the entire tuner range is displayed.

Modification of the sweep circuitry to incorporate Joe Carr's DAC⁴ would also be beneficial, but I won't discuss that here.

I wasn't able to obtain cable tuners above 1800 MHz. It would be nice to display the entire range of 100 to 1000 MHz while aligning multiplier strips, and it would also be desirable to raise the upper frequency limit as well. However, it is possible to extend the range of the analyzer at reasonable cost.

Achieving higher frequencies

Figure 5 demonstrates how to achieve higher frequencies. First, you need to find a swept frequency source at a reasonable price. Backward-wave oscillators were used in older commercial oscillators and YIG oscillators are used in more modern equipment. Both offer wide bandwidth, but for a price! Microwave VCOs offer a bandwidth of 1 GHz or more when tuned with a voltage from 0 to 20 volts. Some of these devices are reasonably priced, have output lev-

*MiniCircuits, P.O. Box 7128, Branson, Missouri 65615. Phone: (417)335-5945.

**Science Workshop, Box 310, Bethpage, New York 11714.

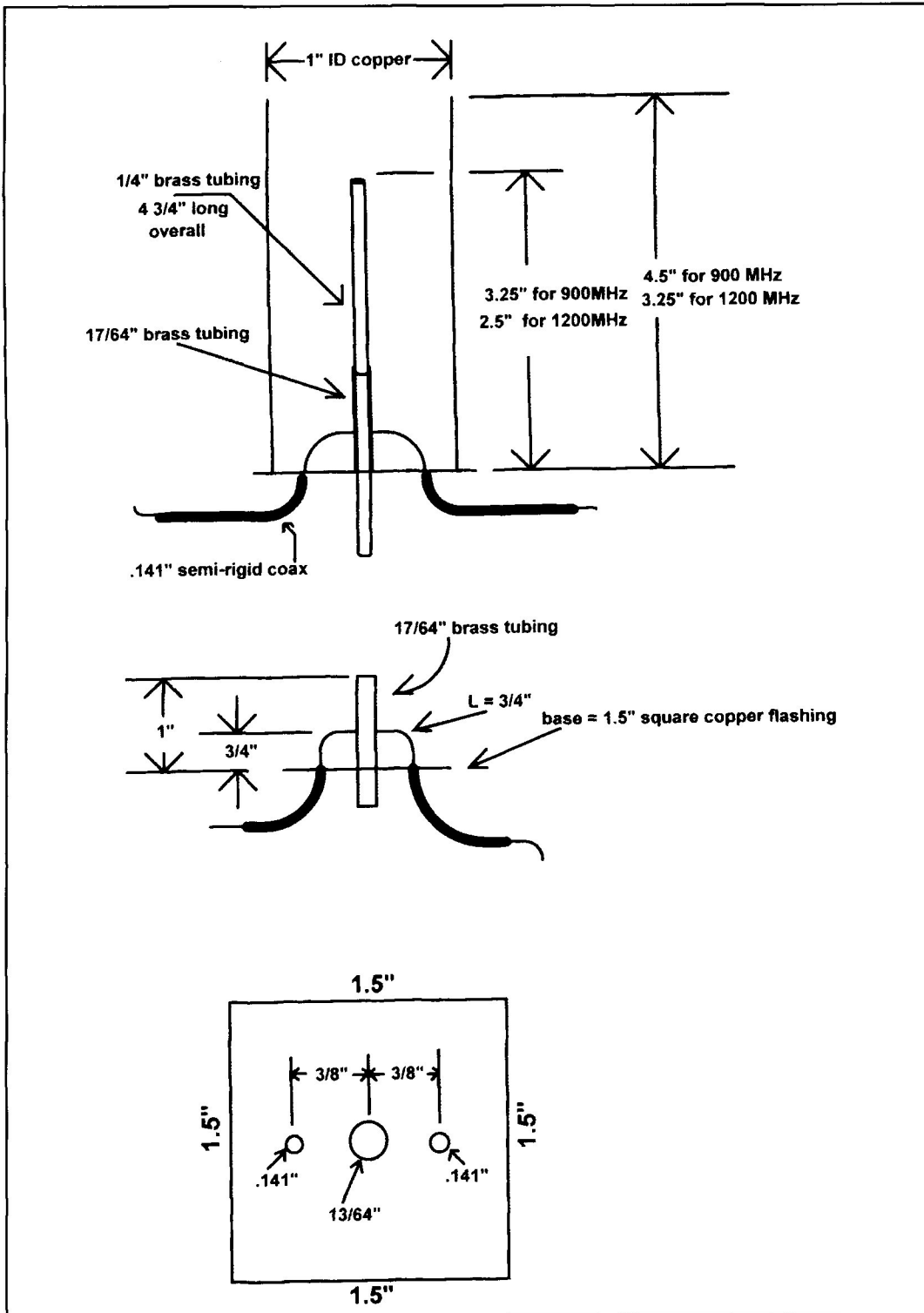

Figure 7. Coaxial filters.

the bottom of the VCO from the ground plane, improved the performance.

A second converter

A second converter (**Figure 6**) uses a Wireless Radio model SM3-3000 VCO cover-

ing from 2650 to 3700 MHz. A MiniCircuits SKY 5G mixer was needed because of the higher frequency ranges. A 900-MHz IF yielded a display range of 1750 to 2800 MHz. The image frequency is 3650 to 4600 MHz. These units are usable "as is" if you know the range of frequencies you're dealing with. If neces-

sary, a highpass or lowpass filter may be used ahead of the converter.

The interface of the VCO to the ERA2 buffer presented some problems. A MiniCircuits PAT3 pad seemed to work best, with a capacitor of 6.8 pF. A bit of experimentation is needed to achieve a constant output over the frequency range. This circuit worked for me, but injection is inadequate over a small range of frequencies. Although this hasn't been a problem, more work may be needed. The VCO should be mounted close to the DBM to keep the interconnecting trace short.

The coaxial filters (Figure 7) are made from 1-inch ID copper water hammer arresters. They are cheap at hardware stores, as are the hobby brass tubes used in the rest of the filter. The center tube extends 1/4 wavelength into the assembly. I got this idea from Reference 5; Reference 6 describes the theory.

The converter outputs are connected to the microwave tuner supplied by Science Workshop. The sweep is removed from the tuning port. For a 900-MHz IF, the tuning port is tied to ground; for a 1200-MHz IF, a positive 5.9 volts is applied. The correct tuner frequency may be verified by checking the LO frequency, which should be at 1266 MHz.

Calibrating the frequency display

The easiest way to calibrate the frequency display is to set a signal generator to display a

low-level signal at the frequency of interest, and sample the generator frequency with a counter. Figure 4 details a simple generator circuit using a new MiniCircuits VCO that covers from 940 to 2400 MHz. Operating the generator in the vicinity of the analyzer will provide a low-level signal on the display. The counter circuit described earlier provides the frequency readout. Additional higher-frequency VCOs may be acquired to extend the range.

These circuits work well for the alignment of multiplier strips, the detection of unwanted RF energy, etc. While lacking the features of commercial units, they do work well and are inexpensive. Recent advancements in microwave VCOs and lower-cost mixers make this a very sensible and very affordable project. ■

REFERENCES

1. Robert Richardson, W4UCH, "Low-cost Spectrum Analyzer with Kilobuck Features," *Ham Radio*, September 1986, page 82.
2. Murray Barlow, WA2PZO, Ham Radio, "Add a Digital Readout to the Poor Man's Spectrum analyzer," *Ham Radio*, September 1988, page 84.
3. Adelbert Kelley, "Wideband Frequency Analyzer," *Ham Radio*, September 1989, page 9.
4. Joe Carr, K4IPV, Ham Radio, "Revisiting the Poor Man's Spectrum Analyzer: Digitally Generated Sawtooth (and Other) Waveforms," *Ham Radio*, September 1987, page 49.
5. H. Paul Shuch, "Lowcost SPELLING????? Microwave Spectrum Analyzer," *Ham Radio*, August 1977, page 54.
6. *The ARRL UHF/Microwave Experimenters Manual*, American Radio Relay League, Newington, Connecticut, pages 6-33.

BIBLIOGRAPHY

1. "Spectrum Analysis," Hewlett Packard application note 150.

PRODUCT INFORMATION

PACE® Complete SMT/Thru-Hole Rework System

PACE, USA announces the PRC 1500, a complete conductive and convective rework system for the benchtop. The system is ideal for rework or assembly of any thru-hole, surface mount, or mixed technology printed circuit board. The PRC 1500 combines the MBT 250A system for conductive SMT/Thru-hole assembly and repair with the ThermoFlo 200 convective system for SMT installation and

rework, as well as BGA removal. Over 200 tips are available for use with the MBT250A. The TF200 comes with an ergonomically designed hand piece that includes on/off vacuum control. It also offers a wide variety of nozzles to fit most surface mount components.

The PRC 1500 comes with four conductive SensaTemp handpieces: the PS-80 Soldering Iron, the SX-70 Sodr-X-Tractor, the TP-65

Thermopik, and the TT-65 ThermoTweez.

For more information, contact PACE by calling 888-535-PACE (7223), via fax at 301-604-8782, or by contacting your local PACE distributor. You may also visit the PACE web site at <www.paceusa.com>.

